

Half section view ( 1 : 12 )

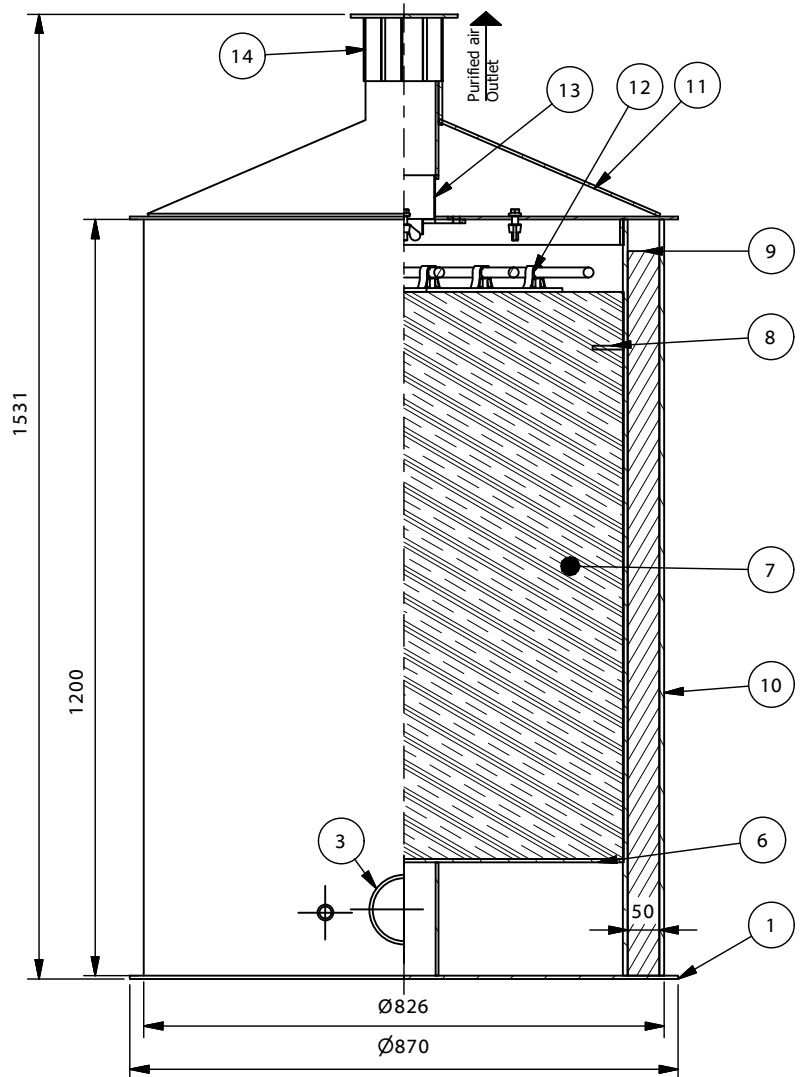

Top View ( 1 : 12 )

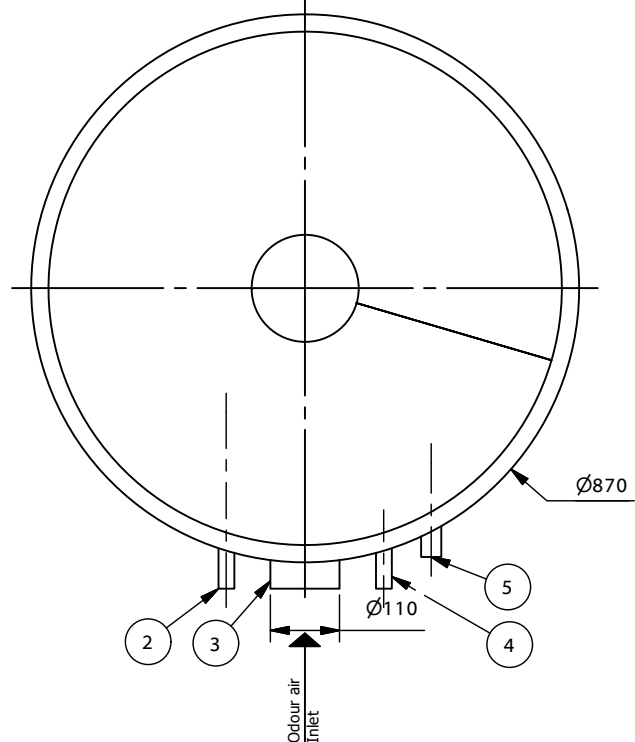

1. Biofilter base plate
2. Spray water inlet
3. Odor air inlet
4. Power supply
5. Spill water outlet
6. Media holder plate
7. Filter media
8. Air guiding plate
9. Insulation (optional)
10. Biofilter body
11. Cover
12. Spray system (only for active system)
13. Fan (only for active system)
14. Purified air effluent



TYP:

**VENTUS 30**

Info drawing

[www.pureco.hu](http://www.pureco.hu)

M= 1:12

**VENTUS** Odor air treatment system

Capacity:	30	m <sup>3</sup> /h
Efficiency:	95	%
Max element weight:	20	kg
Weight:	130	kg